

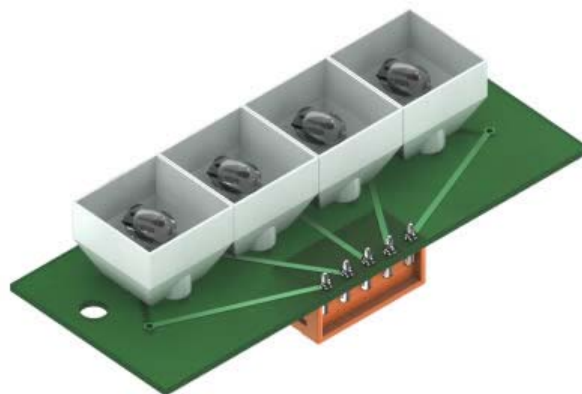

Illumination for information displays

Code 8939310400

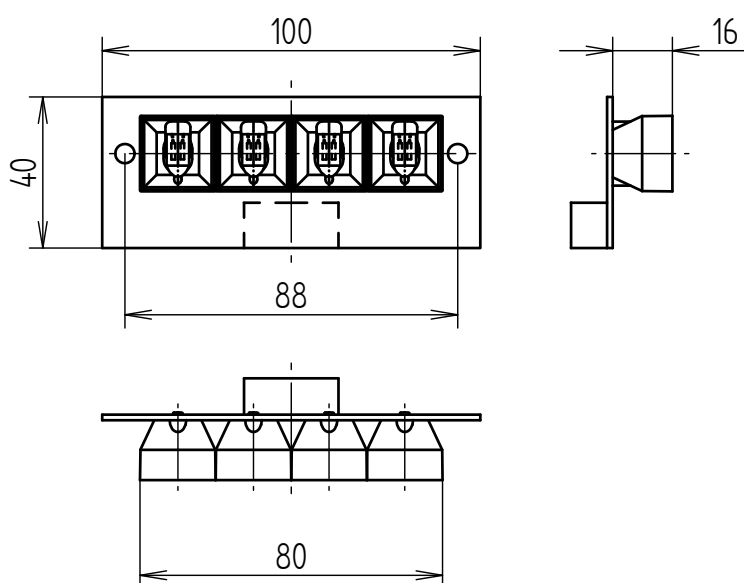

Tolerances unless otherwise stated: ± 0.2

Scale: 1:2

This product is an example of our design and production possibilities in the field of illumination and backlighting.

Custom designed for and in cooperation with a manufacturer of professional restaurant and hotel business machines, the initial most important requirements were:

- 1) Low investments in tooling
- 2) Flexibility for alternative executions
- 3) Good illumination of customer's semitransparent information displays
- 4) Good resistance to high temperatures
- 5) Good electric and fire resistance

After to our different proposals, the client ordered us the present product, which meets all requirements. The lighting means are integrated in the housing and a printed circuit board. The different executions can be arranged, because of the low cost for changes on p.c.b.. Before submit product to client, our laboratory tested all prescribed parameters.