

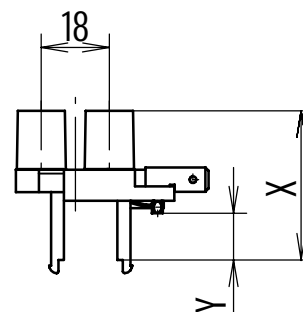

## Quadruple Remaining Heat Indicator Type 475

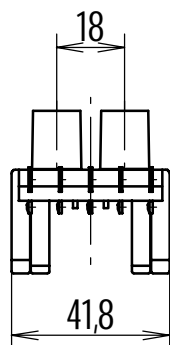

X	Y
33 <sup>+0</sup> <sub>-0,5</sub>	5,5
36 <sup>+0</sup> <sub>-0,5</sub>	8,5

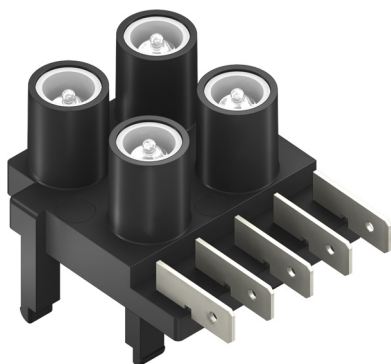
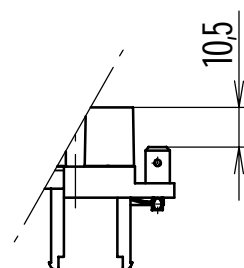
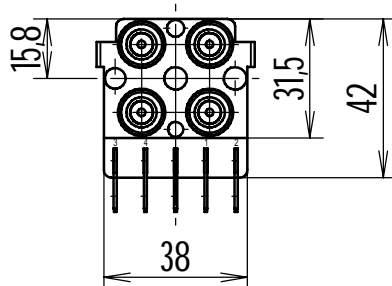

Tolerances unless otherwise stated:  $\pm 0.2$

Scale: 1:2

Quadruple indicator light for building in.

For use at high temperatures as backlighting behind a diffuse panel, f.e. in glass ceramic appliances as residual heat indicator, fixed by snap-in.

Different voltages, connections, brightnesses, resistances to temperature, conformity marks and also with special specifications available.

For details, please see our web page.

### Recommended cutout

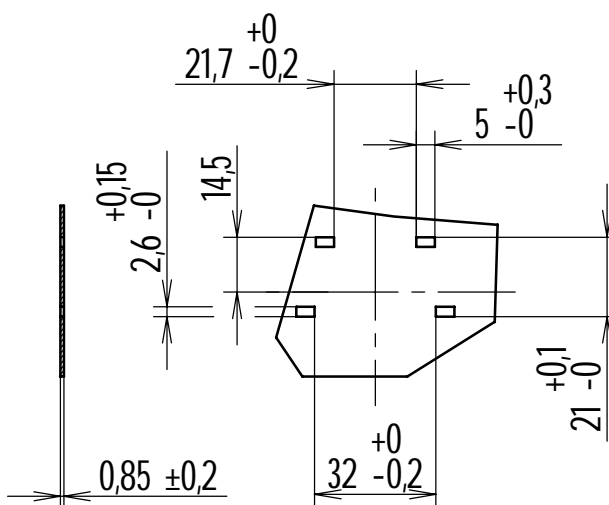

On introducing side no sharp edges!

Scale: 1:2



# electrónica de precisión, s.a.

C./ Galileu, 17 Polígono Industrial Can Estella  
E-08635 Sant Esteve Sesrovires  
BARCELONA

Tel.: +34 93 774 69 10  
Fax.: +34 93 774 65 00  
e-mail: epsa@edep.com  
http://www.edep.com



## Technical specifications series 475

This indicator light for building in with up to four incorporated signals is designed for snap-in mounting to rear panel and to be used at high ambient temperatures. The signals can be placed on different positions.

The thermoplastic housing incorporates the fixing elements, the connection means and also the lighting means.

Usually placed behind a diffusing panel (f. e. of ceramic glass), his black housing prevents from not desired light output or contrasts through it. The incorporated white reflectors improve the brightness and optical appearance.

Following specifications are a guide for end users:

**Connection means:** Tabs (male terminals) 6.3 x 0.8 (vertical or horizontal)

**Ambient temperature:** To be used at a ambient temperature of maximum 180 °C or 200°C

**Rated voltage:** 130V (can be used down to 110V), 250V (can be used down to 220V), 400V (can be used down to 370V) for all voltages, please see "Lighting means"

**Nature of supply:** AC and DC

**Lighting means** Neon glowlamps

**Colour of lighting mean:** orange

**Applicable standard:** VDE 0710 and, as far es applicable, IEC 598 (EN 60 598)

**Conformity marks:**  available

**Voluntary conformity marks:**  2998, ÜG

### **Notes and other technical specifications:**

**Life expectancy:** The ultra high bright glowlamps have an averagelife of 10.000 hours at ambient temperature of 25°C. These values are given for AC supply and standard types. Hease ask for specifications for other types.

**Other voltages:** Under request also other voltages for different natures of supply can be offered.

**Other ambient temperature:** If the indicator light has to work at other ambient temperatures, ask for special quote.

**Brightness:** Our indicator has a very high brightness light output. Other brightnesses available under request. The life expectancies vary from those specified above.

### Order Instructions

For orders, please indicate: Type reference, number of signals and, if less than four, also his position, nominal voltage, connection means (in detail), ambient temperature of use and prefered height (between panels).

Examples Indicator light, quadruple, 475, 250V, horizontal tabs 6.3 x 0.8, 180°C, height 36, or Indicator light type 475, triple (position detailed on sketch), 130V, 200°C, vertical tabs, height 33

Any special requeriment (f. e. specific plastic raw material, other ambient temperature, other lighting means, other voltages, other connection means, a. s. o.) is considered a special execution and his supply and order identification has to be confirmed specially by us.

These details are necessary for the first order and to be in accordance with the prescriptions of product identification of the standard(s) and (or) of the certification institute(s).

For following orders this can be substituted by a code of ten numbers which we assign toall our products and coincides with our drawing number, which usually has to be made to assure corect product identification.