



# electrónica de precisión, s.a.

C./ Galileu, 17 Polígono Industrial Can Estella  
E-08635 Sant Esteve Sesrovires  
BARCELONA

Tel.: +34 93 774 69 10  
Fax.: +34 93 774 65 00  
e-mail: epsa@edep.com  
http://www.edep.com



Switchboard for  
Electronic Panel  
Code 8949720401

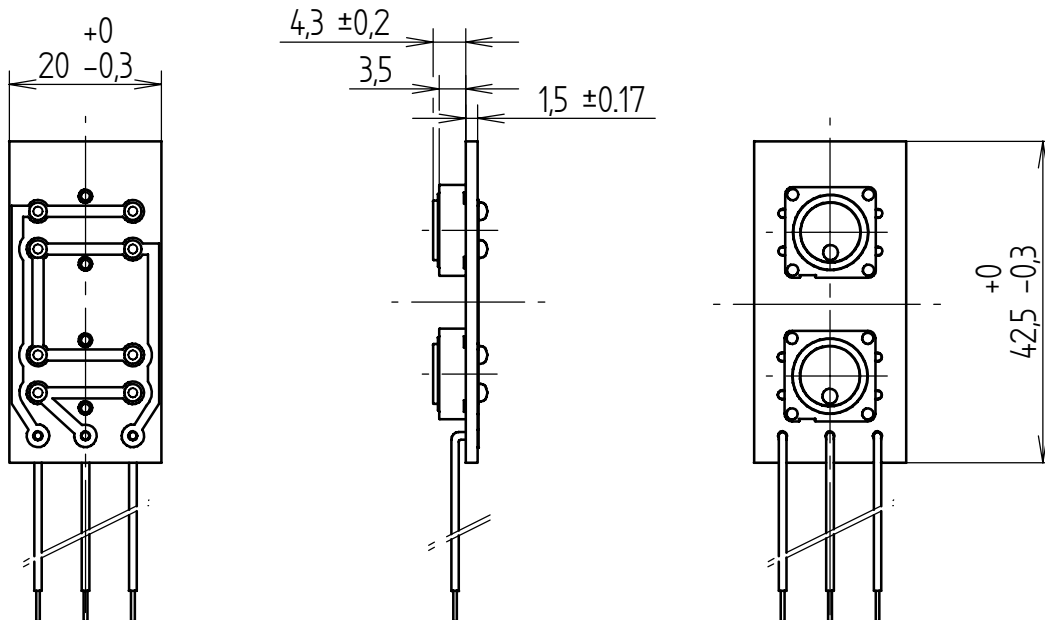
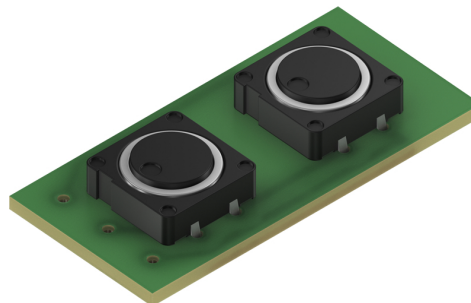

Tolerances unless otherwise stated:  $\pm 0.2$

Scale: 1:1

This product is an example of our possibilities in the field of customized products.

The application was on an electronic soldering machine and the initial most important requirements were:

- 1) Low investments in tooling
- 2) Flexibility for alternative executions
- 3) Very flat housing for actuating device
- 4) Connection by lead wires

After to our different proposals, the client ordered us the present product, which meets all requirements. The different executions can be arranged, because of the low cost for changes on p.c.b.. Customer's panel knobs actuate the switches being displaced by those. Before submit product to client, our laboratory tested all prescribed parameters.